

# Waste Heat Recovery for Commercial Vehicles with a Rankine Process

Dieter **Seher**, Thomas **Lengenfelder**, Jürgen **Gerhardt**,  
Nadja **Eisenmenger**, Michael **Hackner**, Ilona **Krinn**  
Robert Bosch GmbH, Stuttgart, Germany

## Summary

In today's commercial vehicles the heat of exhaust gas and exhaust gas recirculation is emitted as waste heat to the environment. Using a Rankine process, a part of this energy can be converted into mechanical power for usage in the vehicle. Thus fuel consumption and CO<sub>2</sub> emission can be reduced. The two most promising expansion machine concepts, turbine and piston machine are analyzed by simulation and experiment using water as a working fluid. Different working fluids are compared by stationary simulation. The conclusion of this simulation is that the most favourable solutions are a piston machine with water or ethanol as working fluid or a turbine with ethanol as working fluid.

## 1 Introduction

Diesel engines for heavy duty commercial vehicles (HCV) convert in average only approximately 40% of the primary energy into mechanical power. The residual part is released to the environment. The heat of the exhaust gas can be converted into mechanical power for the vehicle by applying a thermodynamic process. A suitable process is the Rankine process.

Research on organic Rankine processes for waste heat utilization in the industry is already reported about in [1]. Applications in combination with combustion engines are discussed in [2]. Due to the low oil prices three decades ago, these approaches were not broadly industrialized. Today waste heat recovery can be an attractive approach to reduce fuel consumption and operating costs. Additionally, the CO<sub>2</sub> emission can be lowered accordingly.

A central component of the process is the expansion machine. The paper at hand compares a piston machine and a turbine for different working fluids on the basis of stationary simulations. Experimental results with the working fluid water are described.

## 2 System

In the following an introduction to the layout and the function of a waste heat recovery (WHR) system is given. In the steam power process, cf. Fig. 1, a working fluid is delivered by a fluid pump from a lower pressure to a higher pressure level and is conveyed through a distributor valve into the evaporators. These evaporate the working fluid with the heat from the exhaust gas. The expansion machine generates power. The steam from the outlet is re-liquefied in the condenser. There the residual heat is released to the cooling system. For conditions such as overrun mode, an operation without energy transformation is necessary. In this case the steam is released via a bypass valve directly to the condenser. A condensate pump delivers the working fluid to the vessel. After the vessel the liquid working fluid is again conveyed to the fluid pump. The system is controlled by a separate Control Unit, which can be realized as a separate component or the system functions can be integrated into an engine control unit.

Different system layouts can be realized including different locations of actuators and sensors. The reasons for this are various customer needs, operating conditions or working fluids. Thus Fig. 1 shows an exemplary system layout.

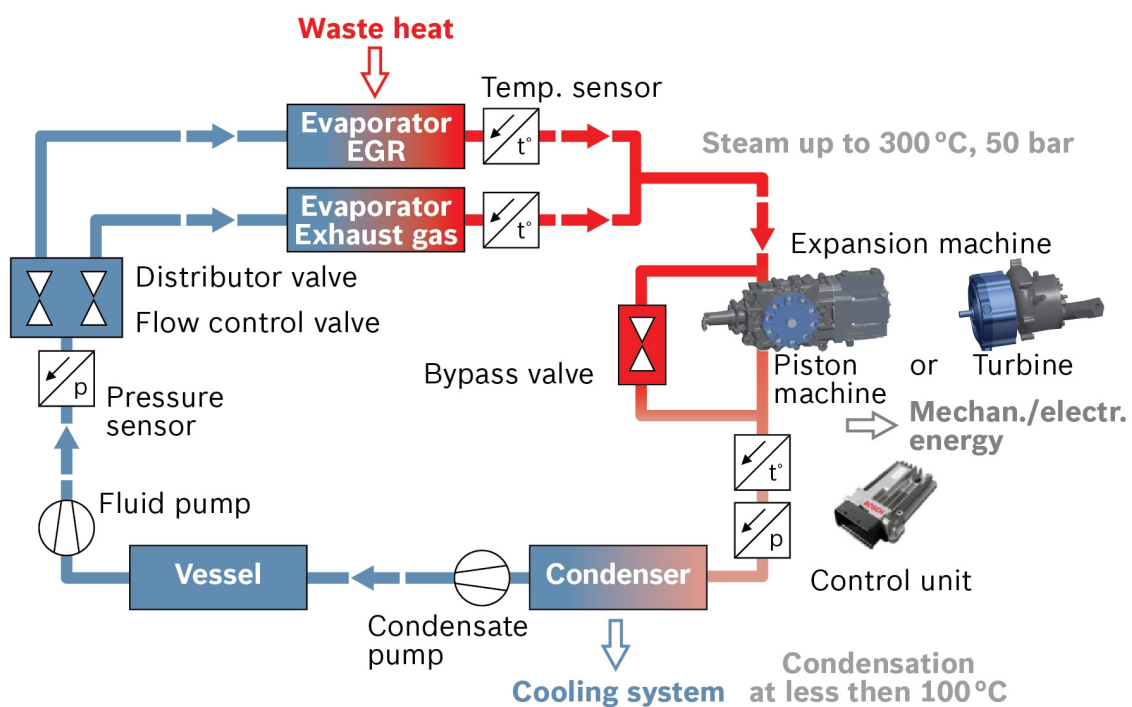

Fig. 1: Example layout for the WHR system

The thermal power input to the WHR system ranges typically from 100 kW to 300 kW. A key component of the WHR system is the expansion machine. The BOSCH group is currently working on two pre-studies for the two concepts piston machine and turbine. These concepts are selected mainly by using the following criteria: thermal / mechanical efficiency, weight, packaging, influence on entire process efficiency, durability and vibrations.

### 3 Utilization Concept

The mechanical energy generated by the Rankine process can be delivered to the engine either directly or via a belt transmission. Compared to an electrical utilization concept the mechanical usage shows the advantage of lower energy conversion losses. A belt transmission has the advantage of reducing oscillations. In case of an expansion machine directly coupled with the engine, significant effort is necessary to dampen unfavourable oscillations.

As an alternative, the expansion machine can drive a generator in order to provide electrical energy. If a piston expander is used, a gearing transmits the speed from engine speed to the working speed of the alternator. In contrast to this conceivable realization a turbine offers the possibility to attach the alternator directly in axial extension of the turbine shaft. This provides the advantage of a compact, integrated unit comprising turbine and high-speed generator. By means of a supplemental transmission, a medium speed generator can be used. Depending on the application, the electrical energy can be stored in a battery, fed to the vehicle's electrical system or it can directly drive an electric machine in the hybridized power train.

As far as the utilization concept is concerned, a clear market tendency can not be identified yet. Thus the BOSCH group examines both, the mechanical and the electrical utilization concept. Ideally, the resulting expansion machine should be able to manage both utilization concepts.

## 4 Simulation and Experimental Results with a Piston Machine

### 4.1 Design of the Piston Machine

The piston expander, shown in Fig. 2, is carried out as a single-cylinder double acting type. The power take-off is at engine speed.

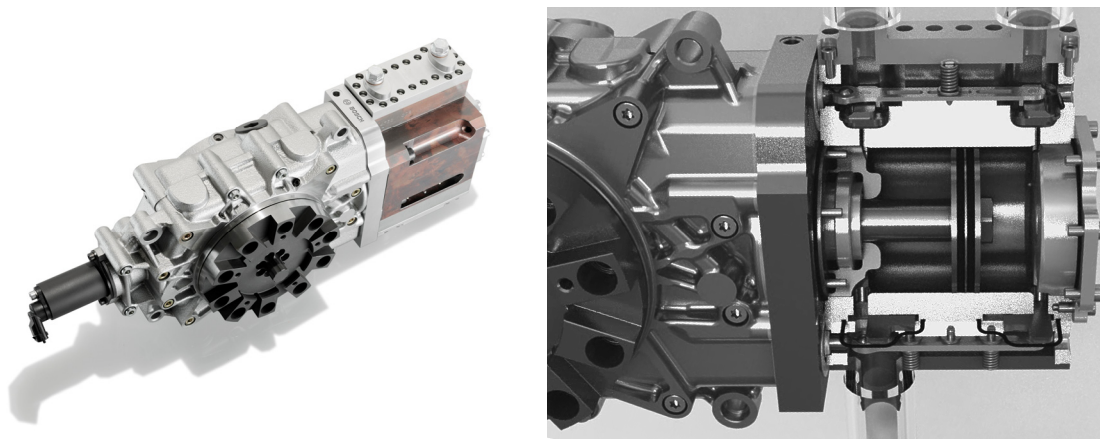

Fig. 2: Prototype of piston machine

Steam enters the chambers by turns and expands in order to produce mechanical work. The steam flow into the cylinder is controlled by gliding valves. Piston rings and valves are not lubricated. Crank drive and valve train are lubricated with engine oil. Appropriate sealing systems separate the steam chamber from the lubricated area. The crank drive is realized as Scotch yoke. This has the main advantage that the piston itself has longitudinal forces only. Transversal forces are intercepted by bushings in which the piston rod is gliding. Another advantage is that this concept needs a low length of the machine compared to an approach with cross-head. Basic data of the piston machine are summarized in Fig. 3.

Displacement [Liter]	0,9
Stroke [mm]	81
Piston Diameter [mm]	87
Working fluids	Water, Ethanol

Fig. 3: Basic data of piston machine

## 4.2 System Model Assumptions

Assumptions for the boundary conditions must be met for each of the different working fluids in order to simulate the Organic Rankine Cycle (ORC). These are shown in Fig. 4. The maximum temperature for the working fluid is determined by the thermal stability of the respective fluid. The pressure on the low pressure side of the ORC arises from the saturation pressure of the working medium at 100°C, respectively. This is derived from cooling system requirements.

The maximum pressure of the working fluid, the gearing efficiency, the pump efficiency, the specific exhaust gas heat capacity, the efficiency of the heat exchanger as well as the minimal temperature difference of the heat exchanger are determined by the constructive design of the system for all working fluids. These parameters are used for both, the piston machine and the turbine.

	Water	Toluene	MM	Ethanol	R245fa
Max. temperature of working fluid at expander intake [°C]	>400	360	270	240	250
Pressure of working fluid at condenser [bar]	1.0	0.7	1.0	2.3	12.5
Maximum pressure of working fluid bar]	40				
Transmission efficiency [%] turbine to engine	85				
Specific heat capacity of exhaust gas [kJ/(kg*K)]	1,066				
Heat exchanger efficiency [%]	90				
Minimum pinch temperature heat exchanger [°C]	20				

Fig. 4: Outline of the boundary conditions for the model

### 4.3 Model Assumptions for the Piston Machine

The piston expander is modelled using a commercial 1D-system simulation tool. The model calculates the state and process variables as a function of the crank angle. The state of the steam is represented as homogeneous within each chamber, i.e. there is no variance with respect to position within the chamber. For the modelling the flow of the fluid at the valves of inlet, outlet and the effective cross-section is taken into account. The four main process steps - steam intake, expansion, exhaust and pre-compression - take into account the parameters displacement, dead volume, valve opening times and the properties of the working fluid. Additionally the impact of pressure losses at inlet and outlet ducts as well as leakage at different parts of the machine is considered for the evaluation of the working process. A p-V-diagram is generated out of the model from which the thermal power output is calculated. For calculation of the mechanical power output the mechanical friction of entire machine is modelled. For this purpose the major areas of friction are evaluated for the model.

#### 4.4 Predicted Results based on Simulation

The performance of the system has been evaluated for different engine operating points of the European steady-state cycle (ESC) for heavy duty vehicles with water as working fluid. Fig. 5 shows the power output based on a 12 l heavy duty engine. The isentropic power is the theoretical peak power output of the piston machine for a reversible adiabatic process. It is derived from the enthalpy difference between inlet and outlet of the machine. The thermal power is the real power of the steam in the chamber. It is obtained from the integration of the calculated p-V-diagram. The power output additionally takes into account the friction of the machine.

Choosing B75 as operating point the effective power output of the piston machine amounts to 12 kW, cf. Fig 5. This is approximately 5 % of the power of the Diesel engine. At the operating point B25 the power output of the piston expander is still approximately 4%.

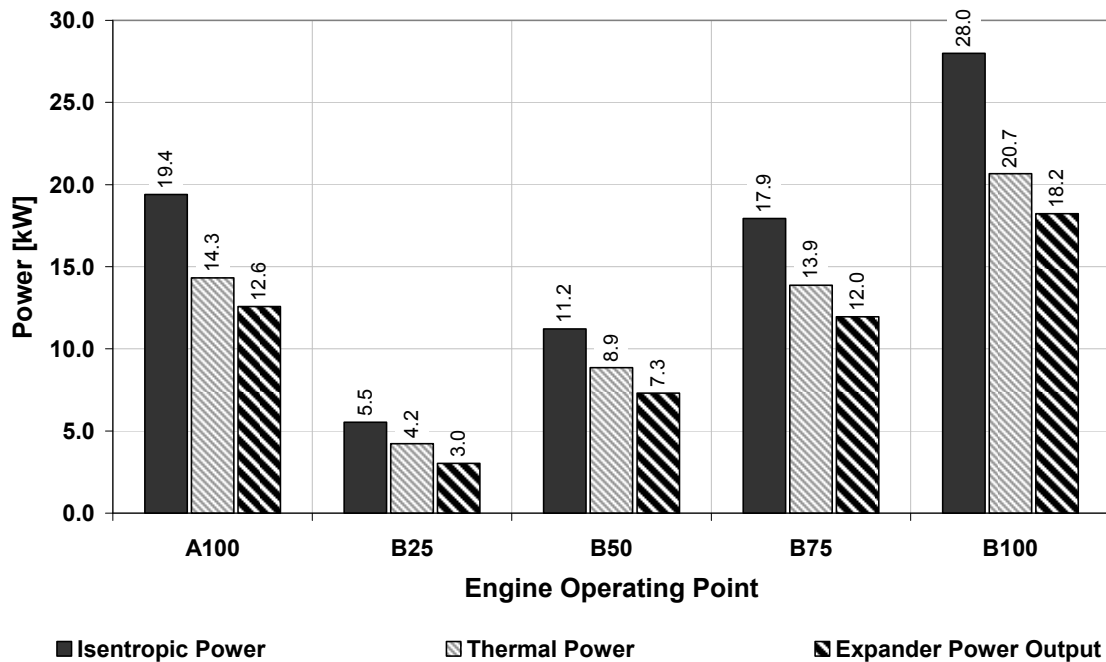

Fig. 5: Calculated power output of the piston machine with water as working fluid

#### 4.5 Experimental Set-up

For the testing of the piston expander the entire waste heat recovery system is realized in a test rack, see Fig. 6. The heat source is a 12 l heavy duty engine. The heat exchangers of exhaust and EGR are prototypes aimed for a WHR system. For measurement of the expander output power a hydraulic machine is used. Thus the speed of the expander can be controlled during the operation of the piston machine. Since the piston machine prototype does not have an own starting feature, the load unit can also be used for starting the machine.

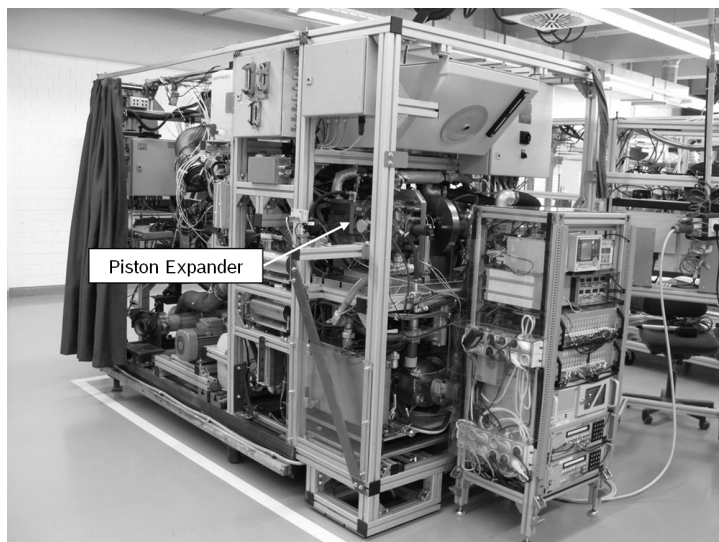

Fig. 6: Waste heat recovery system in a test rack with engine

#### 4.6 Experimental Results

With the setup described above first measurements with the first prototype were performed using water as a working fluid. Mechanical output power up to 14 kW was realized. This amounts to about 4.3% of the engine power at the chosen operating point. The maximum expander inlet pressure is 32 bar, the maximum inlet temperature 380°C. The thermal power calculated from a measured p-V-diagram and the mechanical power output measured show a mechanical efficiency better than 85% at 1500 rpm. This is in accordance with the simulation shown in Fig. 5.

The expansion machine for these first tests was not insulated and not heated by steam. With these measures the efficiency and hence the power output can be improved significantly.

### 5 Simulation and Experimental Results with a Turbine

#### 5.1 Layout of the Turbine

The turbine prototype, Fig. 7, is realized as a double-stage constant-pressure turbine. It is designed for a Rankine process operated with water as a working fluid. The turbine is optimized for a stationary operating point B75 at a speed of 150,000 rpm. The first prototype has a modular design allowing experiments with different nozzle and blade geometries. A turbocharger compressor serves the turbine as a load. The effective output is determined by the measurement of the temperature, the pressure and the air mass flow before and after the compressor. For a series application with a mechanical use of energy, a transmission replaces the compressor. In case of an electrical use of energy, the compressor will be replaced by an alternator.

The boundary conditions for maximum temperature, maximum pressure and maximum power are the same as for the piston machine. In case of mechanical usage, the power can be transferred to the engine via gear drives and a clutch.

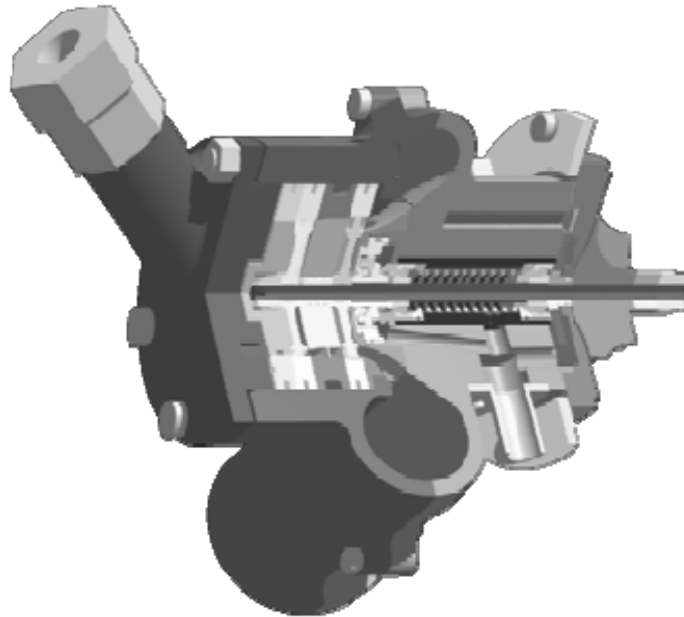

Fig. 7: Cross-section of the turbine prototype

## 5.2 Model Assumptions of the Turbine

In order to simulate an Organic Rankine Cycle (ORC) appropriate assumptions for the boundary conditions must be met for each of the different working media. The system parameters are the same as for the piston machine, cf. Fig. 4.

The simulation is done with a commercial 3D CFD-simulation tool. Due to the partial admission flow a 360°-model is used. A model reduction to just one single blade duct does not take into account all flow effects. All simulations consider transient behaviour and a transient interface between rotor and stator.

## 5.3 Predicted Results based on Simulation

Analogous to the piston expander all turbine-based ORC simulations are executed for several stationary operating points of a ESC test cycle with the model assumptions given in Fig. 4. The engine assumed for the simulation is the same as for the piston machine. Fig. 8 illustrates the performance of the ORC at design engine speed and at different load conditions. By means of the simulation, the waste gas conditions have been calculated for three engine speeds (A, B-and C-points) and four load conditions (25%; 50%; 75% and 100%). The B75 load point serves as a basis for the turbine design for the Rankine process utilizing water as working fluid. At this design point, a power of approximately 10 kW can be generated at a turbine efficiency of 66%. Furthermore it becomes apparent that at the design speed (points



at B-speed from engine characteristic map) and 100% of the engine load the turbine delivers a power up to 16 kW. The required power for the fluid pump of approximately 0.3 kW is not subtracted. This corresponds to approx. 5% of the engine power with a turbine efficiency of approx. 68%.

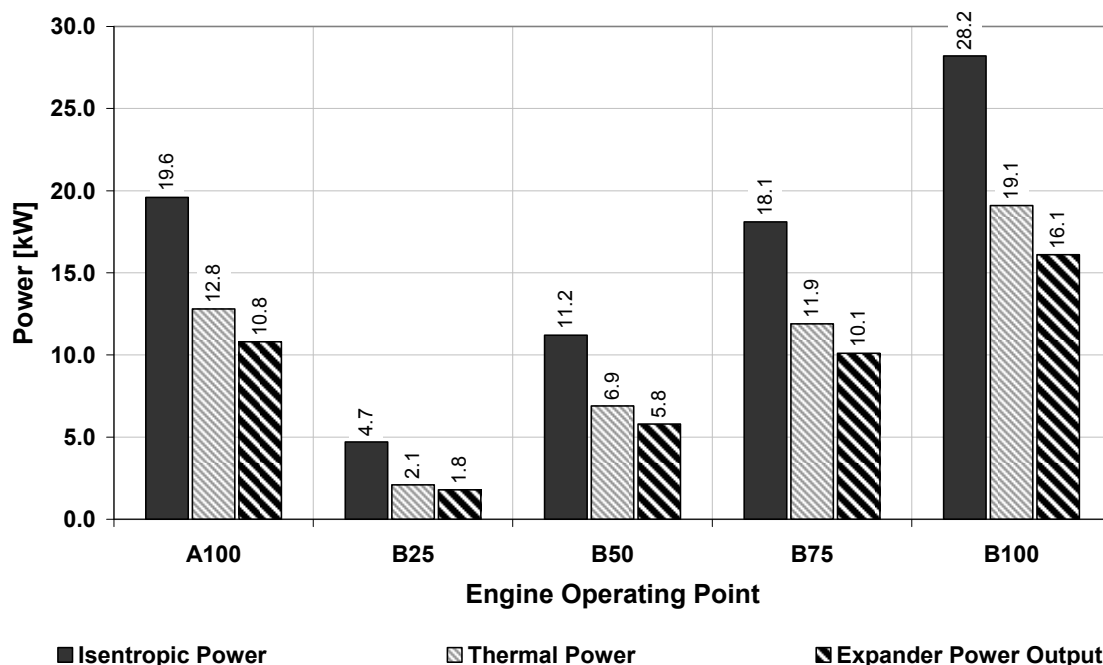

Fig. 8: Calculated power of the turbine with water as working fluid

The model also allows the calculation of efficiencies. For the calculation a simplified model was utilized. It does not consider the spatial flow at inlet and outlet of the turbine as well as the rotor lateral flow. Furthermore all boundaries are assumed as adiabatic and ideally smooth. In Fig. 9 the course of efficiency for different stationary engine operating points is shown. At the operating point B50 the relevant operation speed is between 110,000 rpm and 150,000 rpm. In this speed range the efficiency for B25 decreases significantly. At the other operating points of the engine a high efficiency is visible in the aforementioned speed range, cf. Fig. 9.

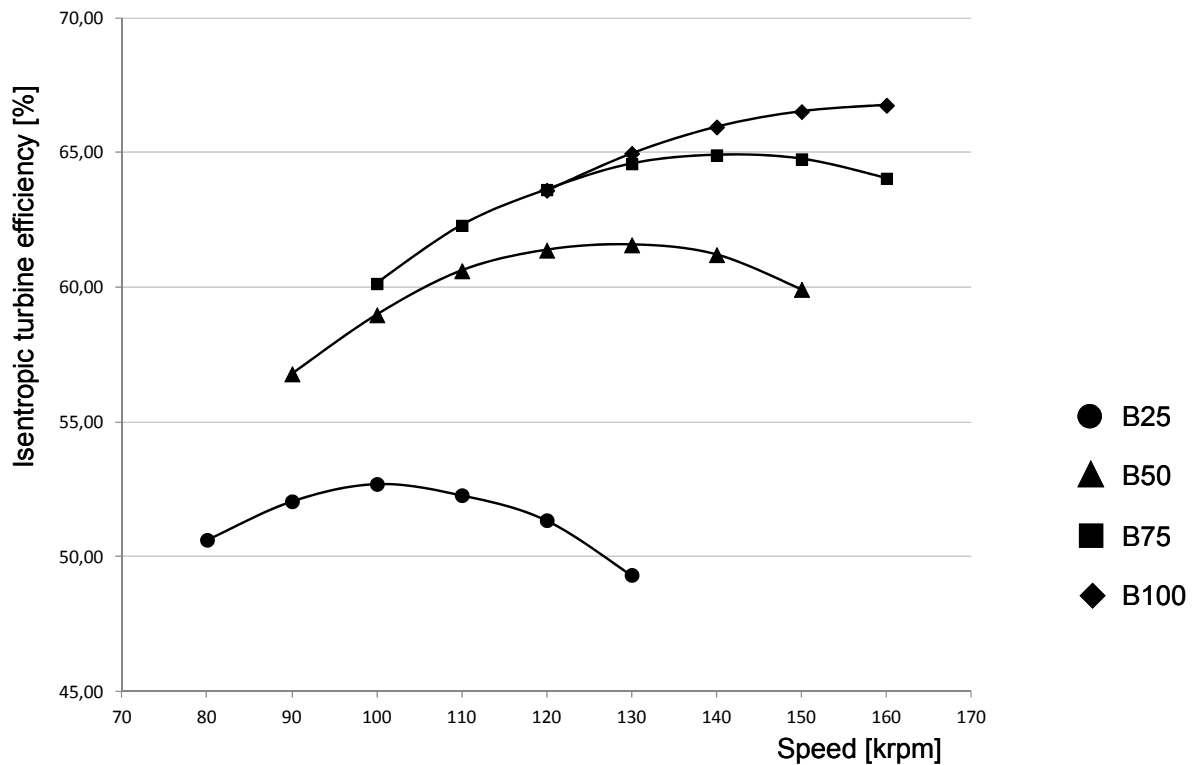

Fig. 9: Efficiency from simulation carried out with a simplified turbine model for water

#### 5.4 Experimental Setup

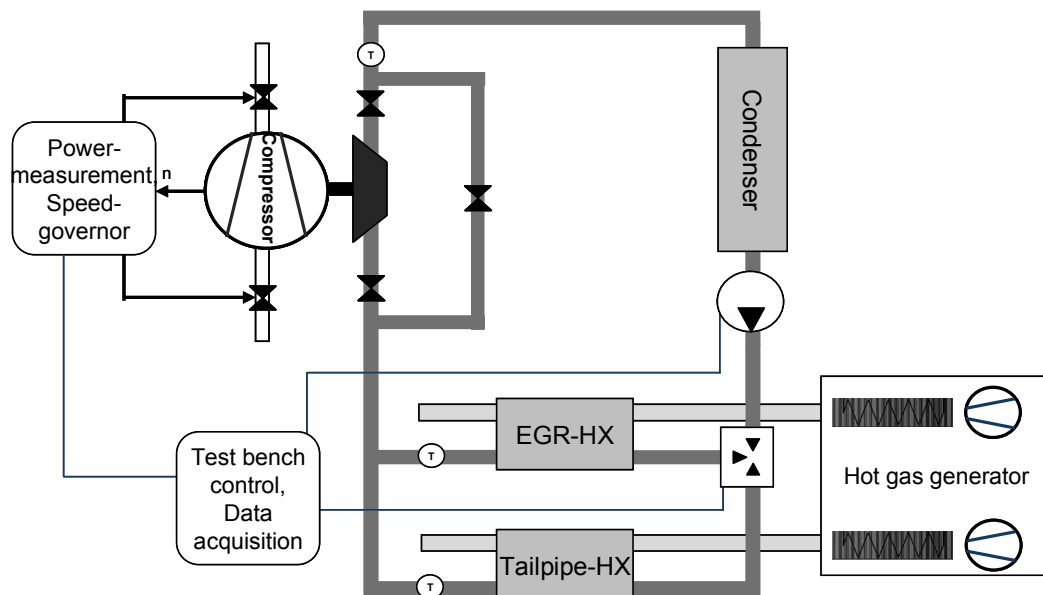

Fig. 10: Sketch of the test bench

As discussed in chapter 2, different topologies of a Rankine process are possible. The experimental set-up for the investigation of the turbine, cf. Fig. 10, is designed and developed for the operation with water as a working fluid.

The system consists of two evaporators in a parallel layout. The system is controlled with a fluid pump, cf. to Fig. 10, which conveys the working fluid via a distributor valve to both evaporators. After the fluid has passed through both evaporators the superheated vapour is released via the turbine. The mechanical energy received from the turbine is dissipated by a turbocharger compressor. The measurement of the resulting power is based on mass flow, pressure and temperature. Downstream the turbine the vapour is re-liquefied in the condenser.

At the test bench two electrical hot gas generators replace the exhaust gas tail pipe. One hot gas generator can provide mass flows of up to 900 kg/h at temperatures up to 550 °C. The second gas generator can provide mass flows of up to 1800 kg/h at temperatures up to 400 °C. Thus the flexible emulation of stationary operating points of a commercial vehicle engine is possible. The evaporators are prototypes developed especially for a Rankine process with water as a working fluid. A photo of the test bench is given in Fig. 11.



Fig. 11: Photo of the test bench for the turbine

Another advantage of this hot gas generator is the adjustability and reproducibility of steam parameters and test conditions. Furthermore the test bench allows low temperatures of the condenser, enabling operation below atmospheric pressure. This allows a high pressure difference with a highly efficient process.

## 5.5 Experimental Results

With the prototype of the turbine, cf. to chapter 5.1, a performance measurement was conducted at the engine operating points B25 to B75, cf. Fig. 12.

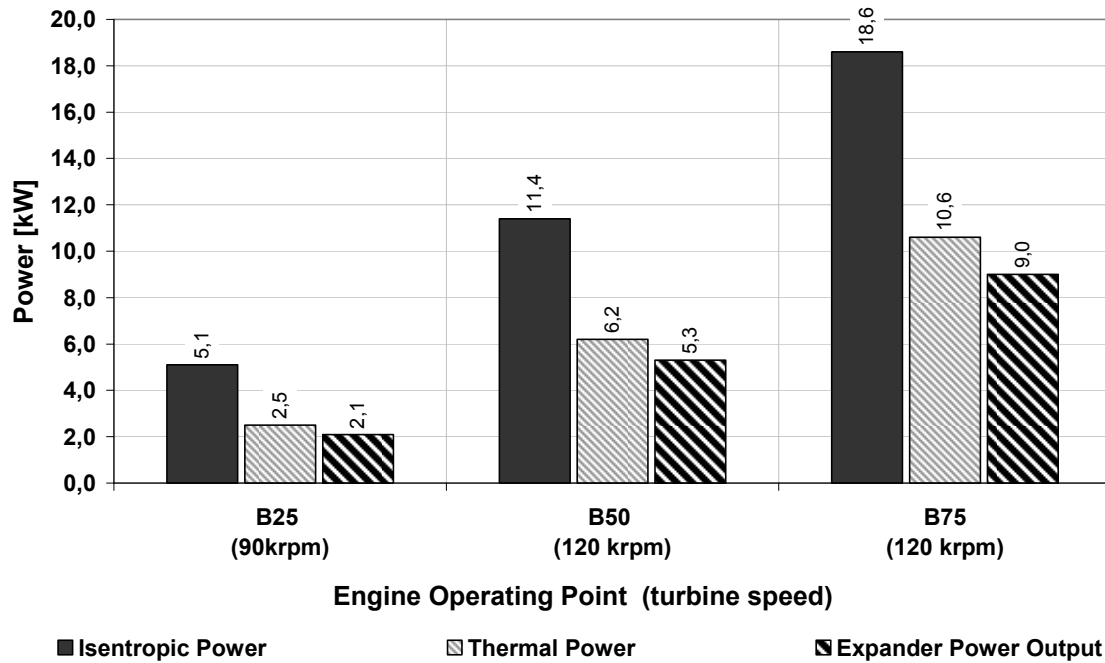

Fig. 12: Measured power of the turbine with water as a working fluid

For each operating point the first left bar displays the isentropic power of an ideal turbine. The second middle bar depicts the thermal power calculated from the measured difference of enthalpy between steam entry and steam exit of the turbine. The last right bar depicts the turbine power output which was measured using the turbo compressor on the turbine wheel.

Compared to the simulation results given in Fig. 8, the turbine prototype shows a lower thermal power for the operating points B50 and B75. Major reasons are different gaps and different surface roughness of the prototype compared to the model assumptions. The prototype was designed with a modular approach enabling the use of different nozzle and blade geometries. As a result of this non-serial design of the prototype leakage occurs. In a series type turbine a significant part of these losses can be avoided.

## 6 Comparison of Working Fluids based on Simulations

Basis of the simulation is the system layout according to Fig. 1, the system parameters of Fig. 4 and the simulation models as described in the chapters before. The engine assumed for the simulation is a 12 l heavy duty Diesel engine. The operating points are based on the ESC.

The fluids water, ethanol, MM (hexamethydisiloxane), R245fa and toluene are considered for the turbine. For the piston machine only water and ethanol were taken into account. The other fluids mentioned above show a poor performance in a piston machine with the given boundary conditions. Due to the high volume flow the displacement of the piston machine would have to be increased significantly, which does not seem feasible.

Fig. 13 shows the power output of a WHR circuit for different fluids at different engine operating points. The ordinate displays the power output of the expansion machine minus the required power of the fluid pump.

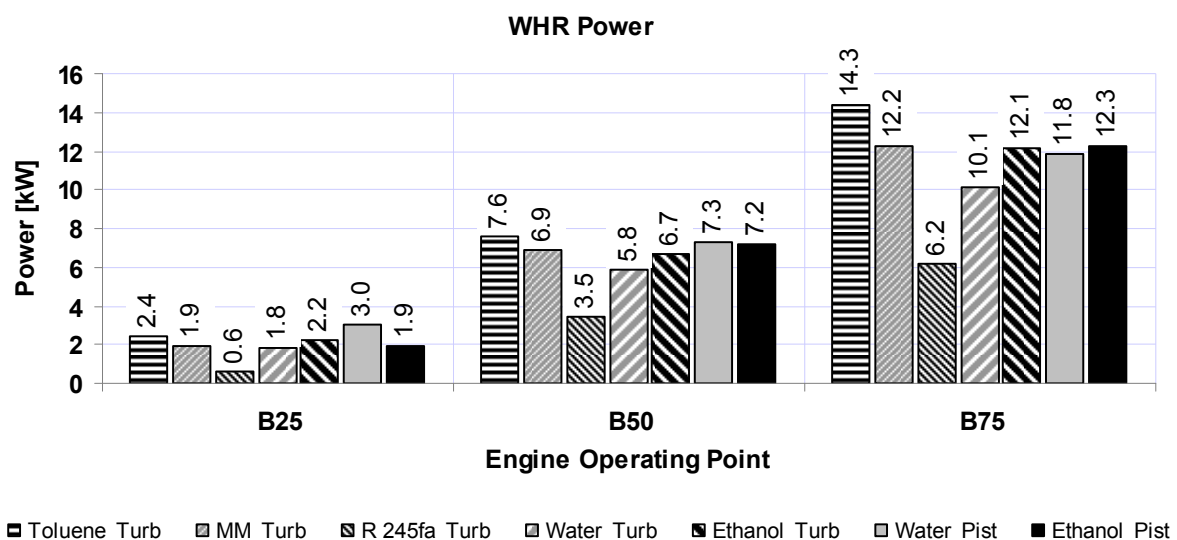

Fig. 13: Power output of the waste heat recovery system

Fig. 14 depicts the ratio of WHR power output divided by the power of the Diesel engine at the appropriate testing point. The maximum power output can be obtained with the fluid toluene using a turbine at B50 or at higher loads. From thermodynamic point of view toluene looks favourable. However, toluene is classified as harmful to health [3] and is therefore not recommendable. R245fa, which represents the fluid group of refrigerants, shows the lowest performance in this comparison. With an assumed condensation temperature of 100°C, the resulting condensation pressure of R245fa is rather high (12 bar). Based on R245fa a significant performance increase can be achieved if the condensation temperature is below 60°C. Finally, R245fa has a high Global Warming Potential (GWP) of 950 [3]. Thus a development to replace refrigerant fluids is expected.

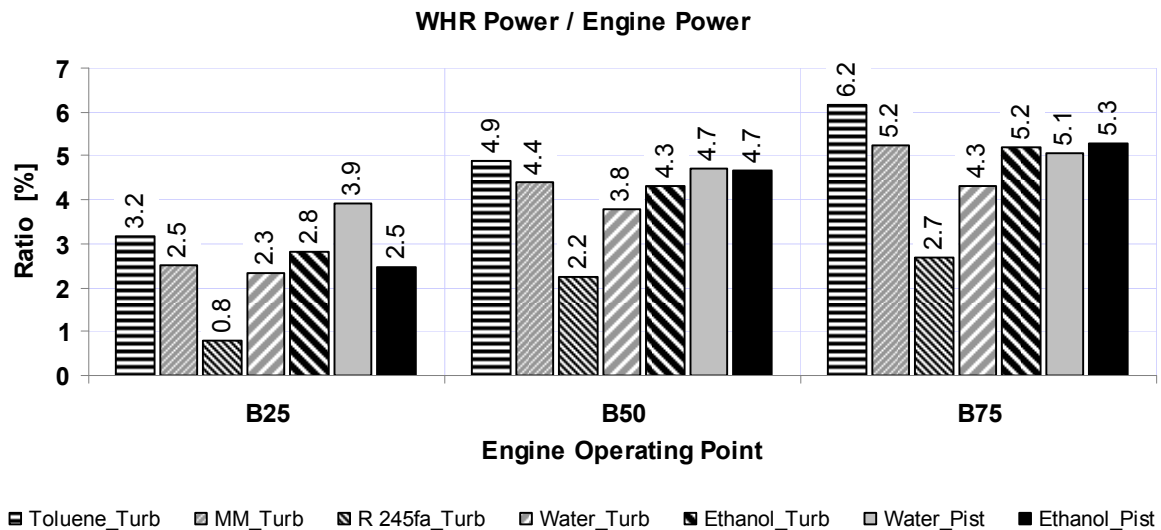

Fig. 14: Ratio of power output of the waste heat recovery system / engine power

MM and ethanol show a similar performance when used in the turbine. Compared to ethanol MM is a dry expanding fluid. Therefore the turbine outlet temperature is high. As a consequence a recuperator after the turbine outlet is needed. It cools down the steam by heating the liquid fluid behind the fluid pump.

Considering the system effort, the fluids MM and refrigerants require a significantly high input power for the fluid pump. In the case of R245fa it amounts up to 2 kW. A sufficiently large pump is required, resulting in packaging issues and in significantly increased system costs.

When used in a turbine, water shows a lower performance than ethanol. The major reason is that the speed of sound of the fluid water is significantly higher than that of ethanol. Thus the volume flow given is not sufficient for a turbine with full admission. Hence the thermal efficiency is lower. Furthermore the rated speed of the turbine amounts to 150,000 rpm, which is high for mechanical usage of the power output. Therefore water is less suitable for a turbine.

In a piston machine water and ethanol show a similar performance at B50 and higher operating points. At B25 the power output with ethanol is lower than with water. The major reason is an over-expansion. This can be improved by reducing the condensation pressure from approximately 2.2 bar to 1 bar. Thus the condensation temperature is reduced from 100°C to 78°C.

The conclusion from the above considerations is that the most favourable solution is either a piston machine with water or ethanol as working fluids or a turbine with ethanol as working fluid.

## 7 Conclusions

The properties of the chosen working fluid heavily influence the key design parameters of the major system components needed to realize an Organic Rankine Cycle to enhance the fuel economy of a heavy duty engine. Derived from the theoretical and experimental results provided by this article, the most favourable solution is either a piston machine using water or ethanol as working fluids or a turbine operated with ethanol.

The layout of an ORC-system is additionally defined by the way how the recovered energy is put back into the powertrain or electric-net of the vehicle. Therefore the standardization of a working fluid is the key for a successful industrialization of an ORC-system.

## 8 Definitions, Acronyms, Abbreviations

EGR	Exhaust Gas Recirculation
ESC	European Steady-State Cycle
GWP	Global Warming Potential
HCV	Heavy Duty Commercial Vehicles
HX	Heat Exchanger
MM	Hexamethydisiloxane
ORC	Organic Rankine Cycle
WF	Working Fluid
WHR	Waste Heat Recovery

## 9 References

- [1] VDI-Berichte 377.  
Capturing Energy from Waste Heat  
VDI-Verlag GmbH  
Düsseldorf, 1980
- [2] VDI-Berichte 539.  
ORC – HP Technology  
VDI-Verlag GmbH  
Düsseldorf, 1984
- [3] GESTIS Stoffdatenbank  
Institut für Arbeitsschutz der Deutschen Gesetzlichen Unfallversicherung (IFA).  
St. Augustin, Germany, 2012