

Challenges of the OEM/Supplier Relationship with Respect to Powertrain Integration



CHRYSLER

Dr. Mircea Gradu

Vice President – Transmission and Driveline Engineering,
Head Virtual Analysis
Chrysler Group LLC

Dr. Hussein Dourra

Technical Fellow
Advanced Powertrain Controls
Chrysler Group LLC



Covered Topics

1. Drivers for Modern Powertrains
2. Industry’s New Challenge With Respect to Powertrain Integration
 - Dodge Charger System Overview
3. OEM/Supplier Relationship and New Approach To Testing
4. Chrysler Specific System Integration Aspects
5. Conclusions



Drivers for Modern Powertrains

- Refinement
- Capability
- Safety
- Fun-to-Drive
- Fuel Economy
- Performance
- Competitiveness
- Others ?

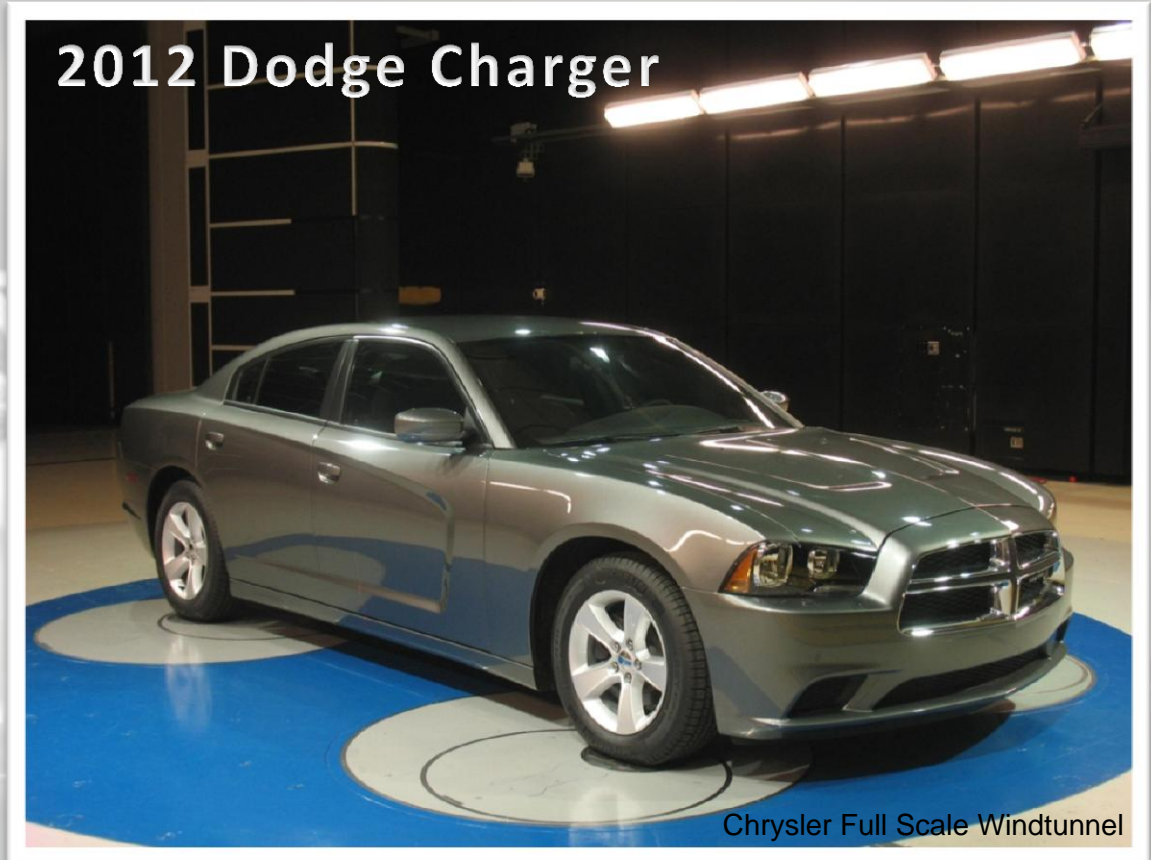

Industry Challenges

- 1) Engineering Partners involvement is **Increasing**
- 2) Testing and Validation requirements are **Increasing**
(components and system level)
- 3) Number of OEM Specific Features are **Increasing**
- 4) Competition is **Increasing**



This implies:

A new approach in testing and validation is required for components and systems



New Challenge to Dodge Charger System

Powertrain component testing and system level integration includes:

Engine
Transmission
Transfer Case
Front and Rear Axles
Prop Shaft and Half Shafts

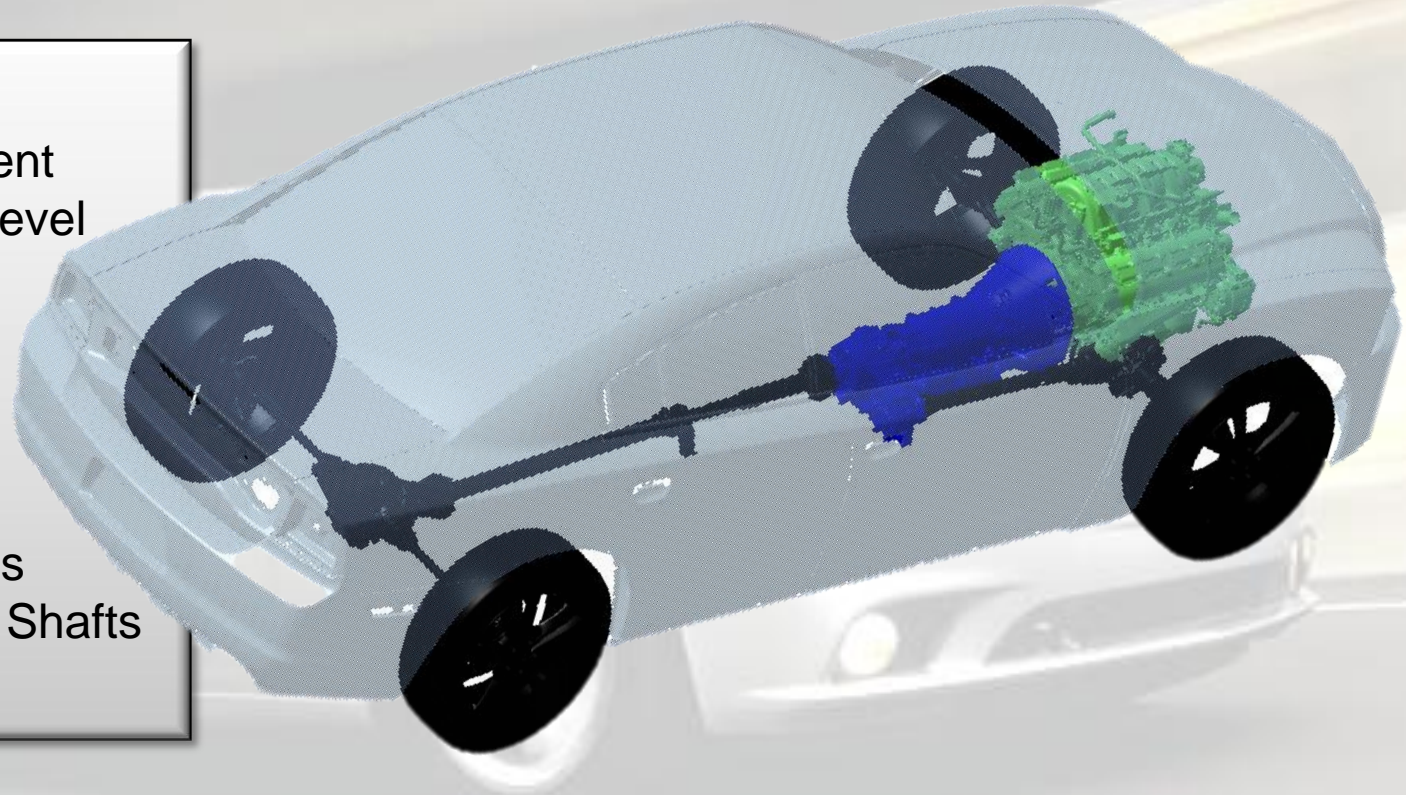

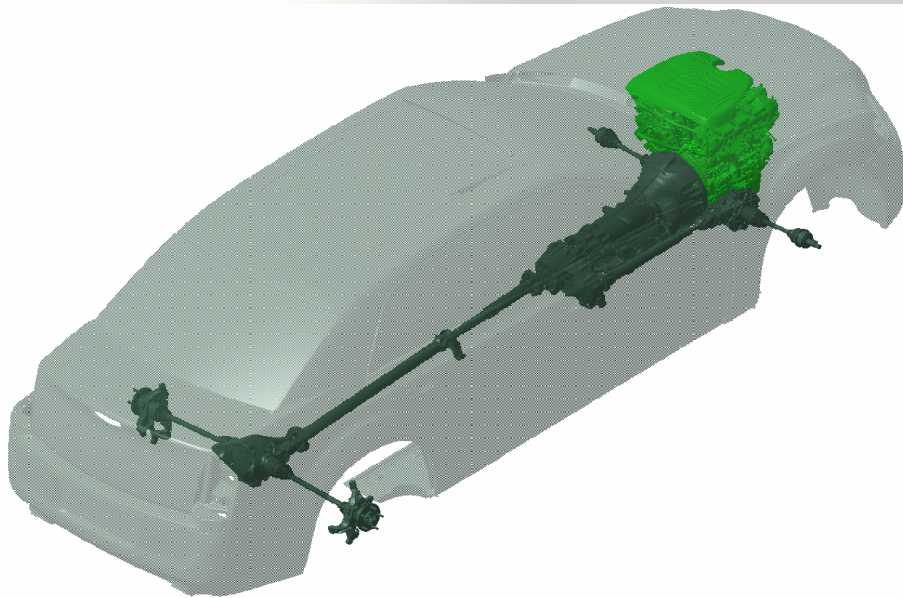

3.6L V6 PENTASTAR

- E85 flexible fuel capable
- Type II valve train with dual independent camshaft phasing
- Variable displacement oil pump

5.7L V8 HEMI®

- "Fuel Saver" Multi-Displacement System (MDS)
- Active intake manifold
- Type V valve train with Variable Camshaft Timing

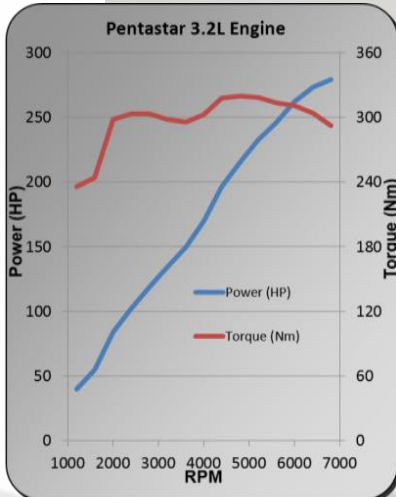

Pentastar V6

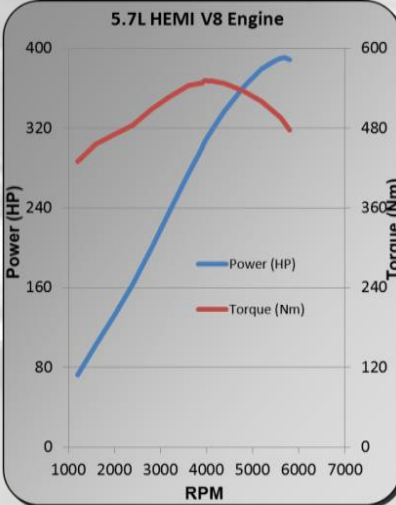

5.7L V8 HEMI®



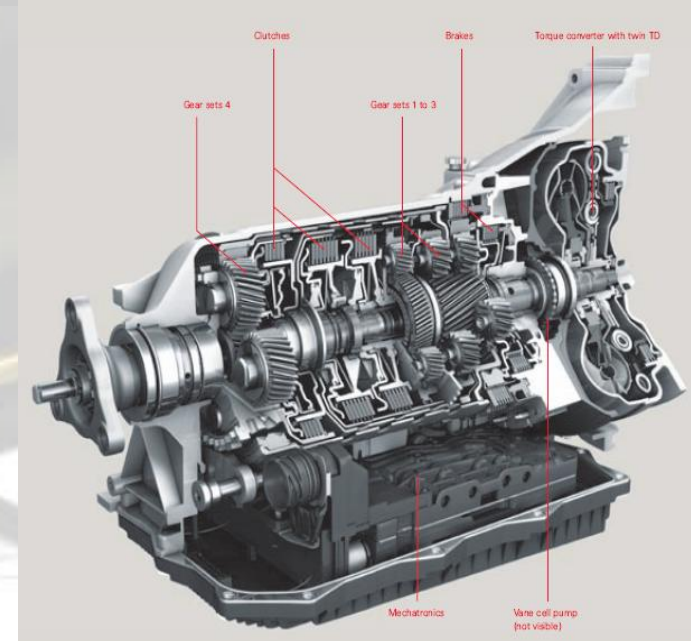
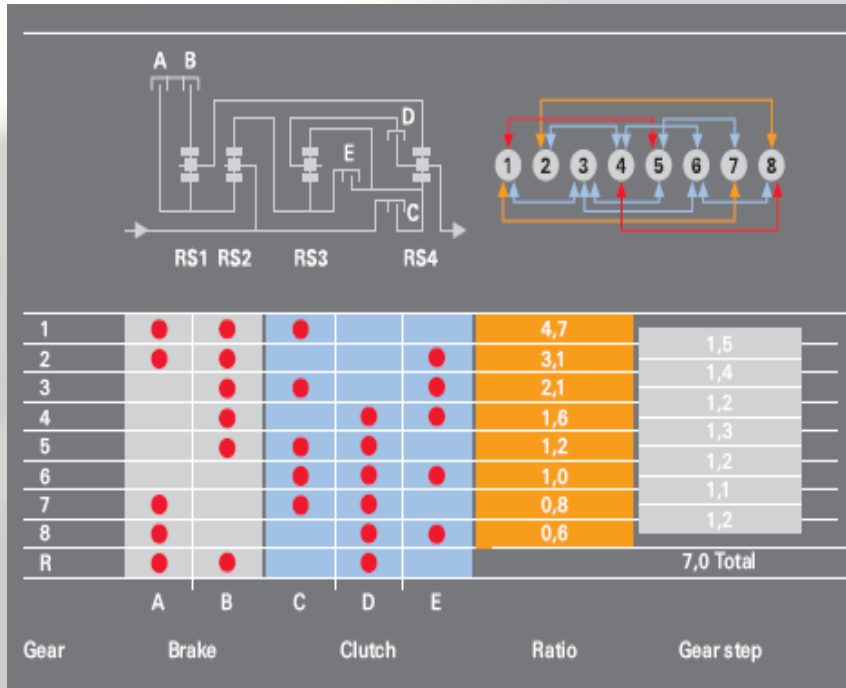

8 Speed Automatic Transmission

- Ratio Spread: 7.03
- EMCC with single or multiple discs
- Torque Converter with turbine- and twin turbine dampers
- Start / Stop Capable
- Hybrid Capable



8 Speed Planetary



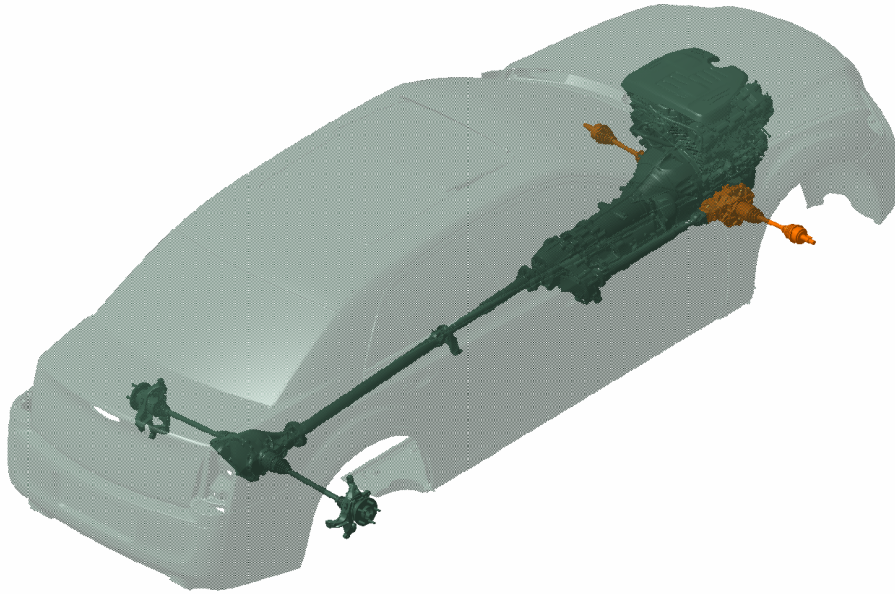

175 mm Front Axle

AWD Front Axle with Disconnect

- 175 mm ring gear with open differential
- Axle Disconnect Unit separate from differential assembly
- Disconnect under control of Transfer Case ECU
 - Electric motor drives shift fork
 - Interrupts powerflow through intermediate shaft



Front Axle Disconnect (FAD)



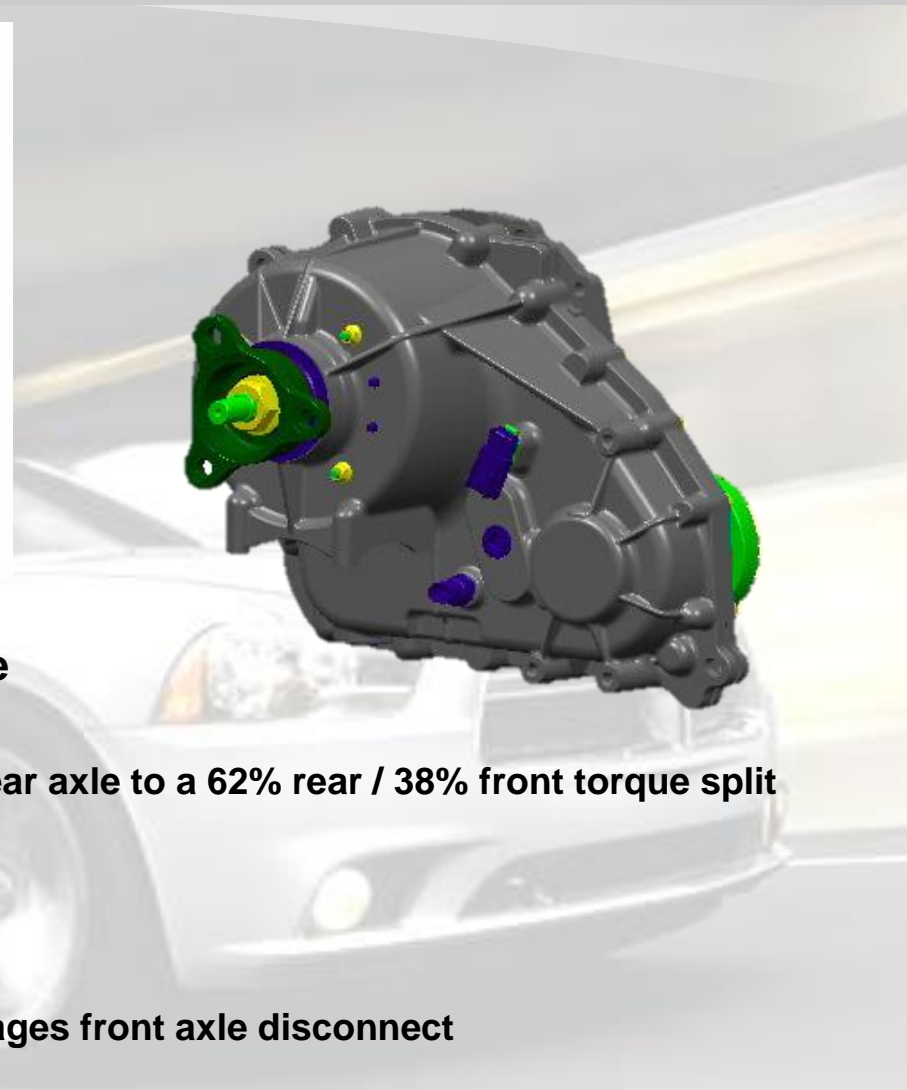
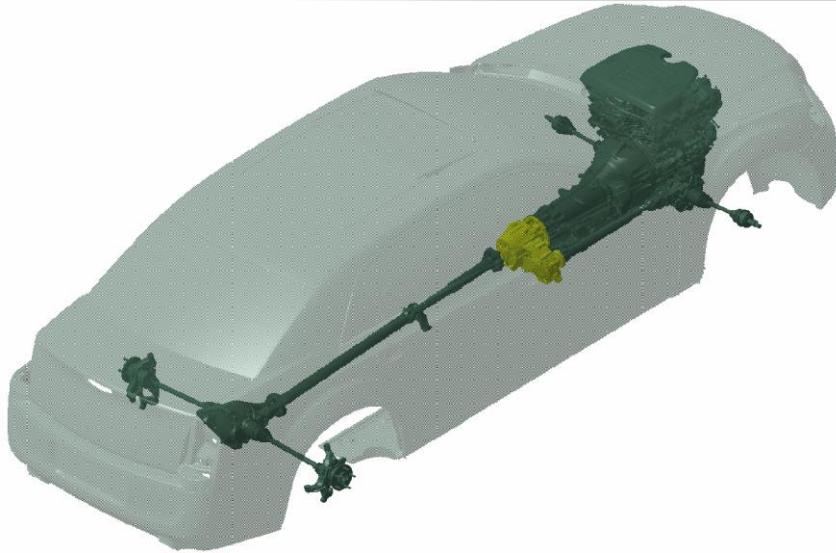

Interactive Torque Management™ Transfer Case

- Active “On-Demand” Transfer Case
 - Varies from 2WD mode with 100% torque to rear axle to a 62% rear / 38% front torque split
 - Maximum of 1100 Nm torque to front axle
- Chain Drive to maximize efficiency
- Auto Front Axle Disconnect (FAD) Control
 - Transfer Case Electronic Control Module manages front axle disconnect
 - Anticipates conditions that may require AWD



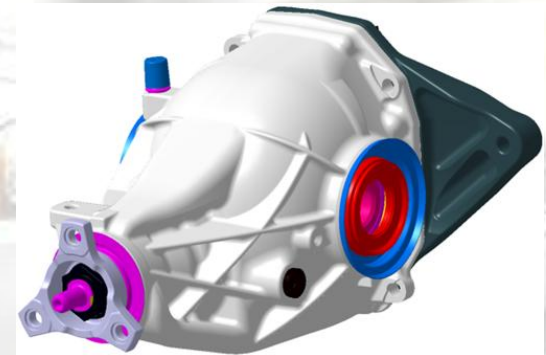
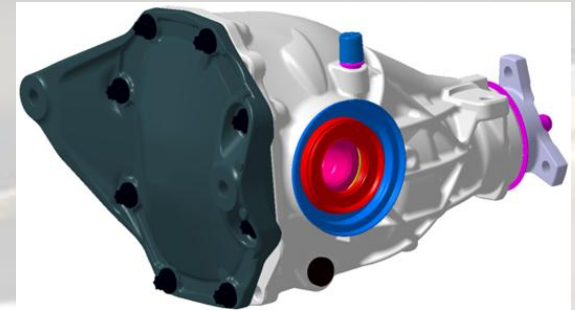
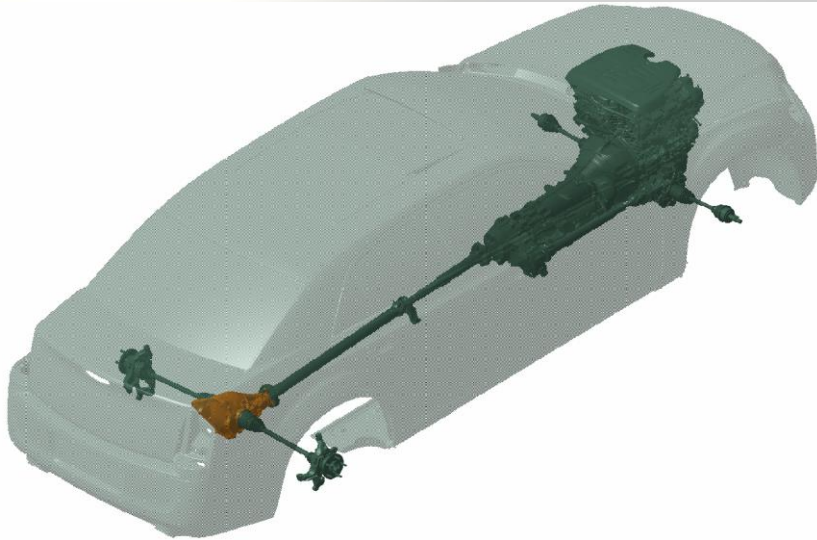

200 mm & 215 mm Open Rear Drive Unit

- Independent Rear Open Differential
- Available Ratio(s):
 - 215 mm - 2.65 / 2.82 / 3.06
 - 200 mm - 2.65 / 3.07
- Plug-in CVJ Output Interface
- Tapered Roller Differential and Pinion Bearings



Industry’s New Challenge With Respect to OEM/Supplier Partnerships

- Competition and Customer demands are forcing a new business model.
- Engineering partnerships are gaining ground in the new business environment.
- The new business model is forcing the OEM’s role to shift to a system level responsibility.

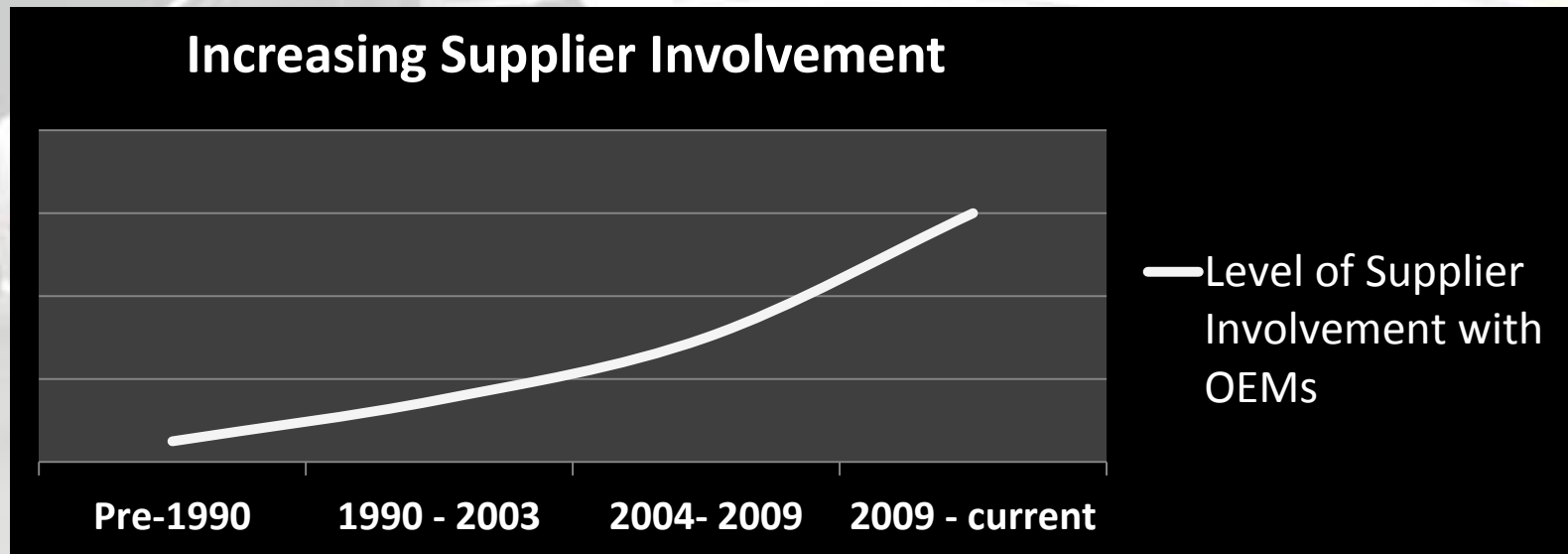

Information shown is a snapshot from historical data



Increasing Vehicle Outsourcing

(percent of car value)

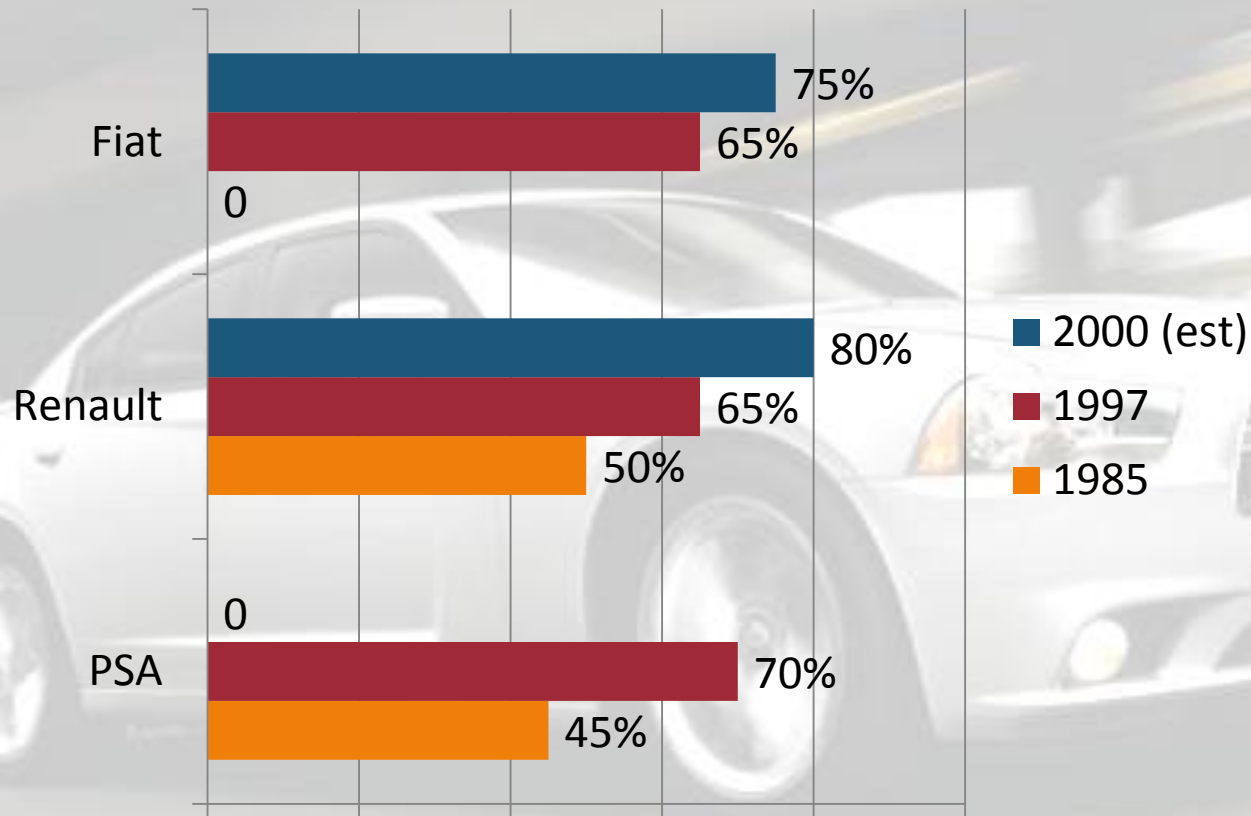

Source: The Economist Intelligence Unit.



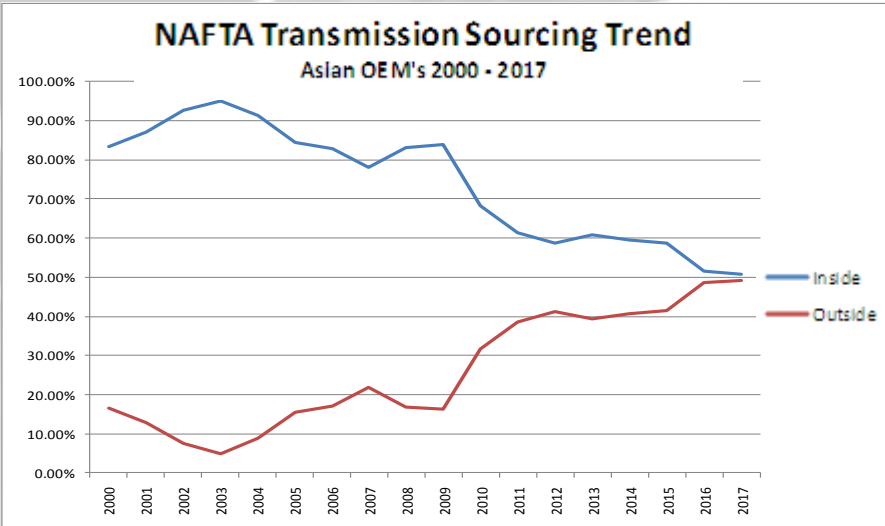
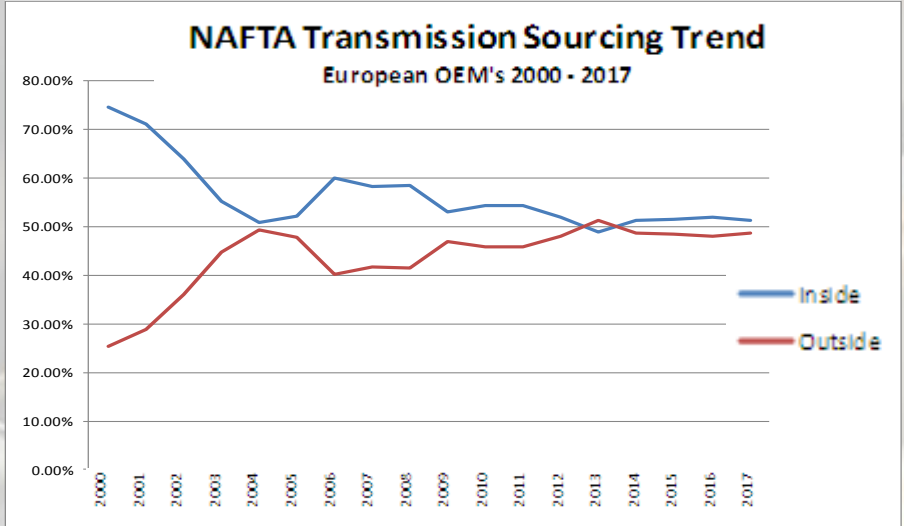
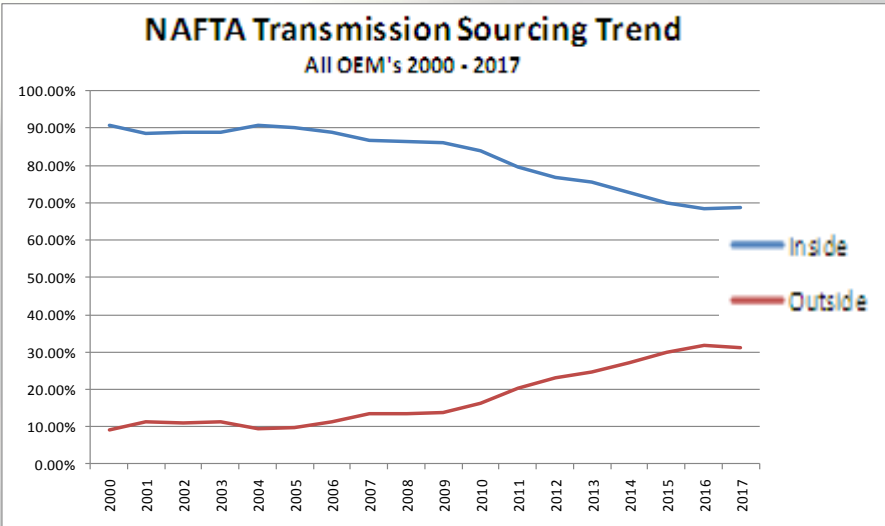

Engineering Partnership is increasing, forcing the OEMs to look for new ways of testing and validation

Source: IHS Automotive



OEM Challenge

- **Engineering Partners supply “Black Box” IP information**
- **OEM is responsible for:**
 - **Component Calibration**
 - **Overall System Testing**
 - **OEM Specific Feature Interaction**



Different Tools and Methods are Required

- Component Calibration
 - Different approach to system calibration is required
- Overall System Software Testing
 - Different tools are needed to test the overall system for failures and issues.
- OEM Specific Feature Functional Interaction



Component Calibration

Utilize vehicle data to evaluate supplier component control functions and understand calibration complexity.

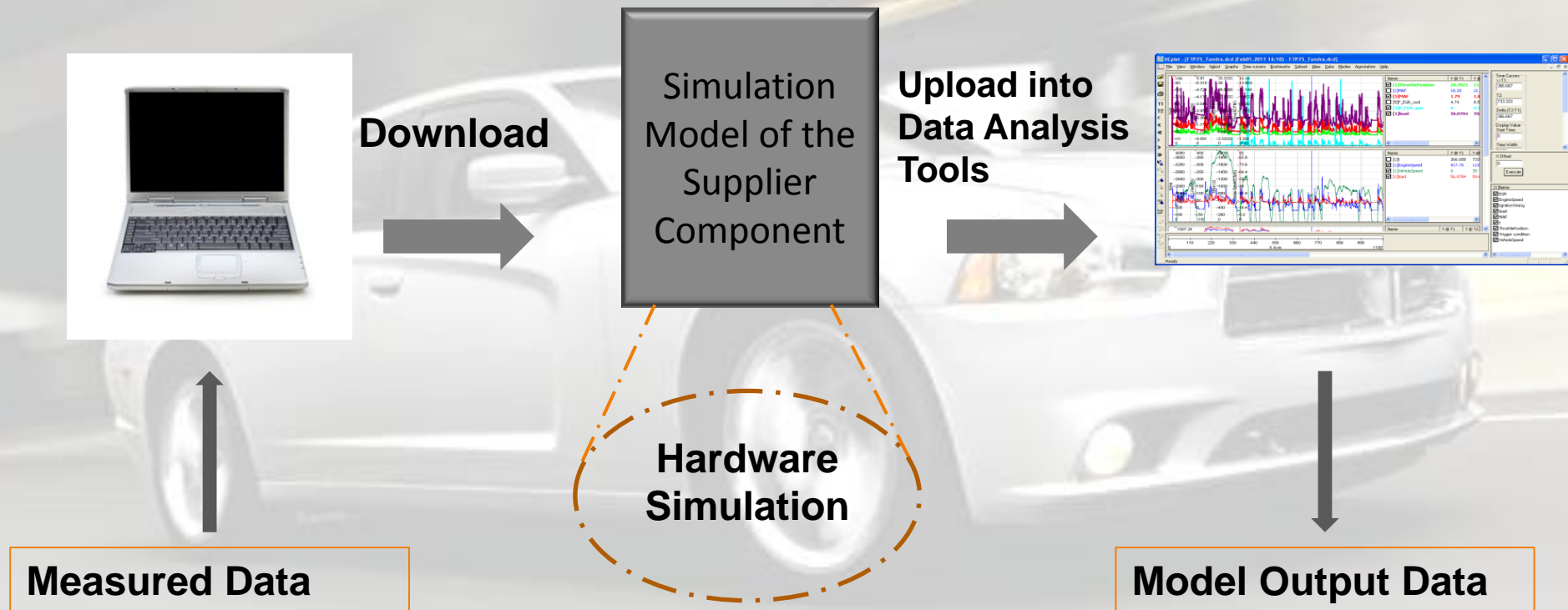

Example: ZF Transmission as an integrated component

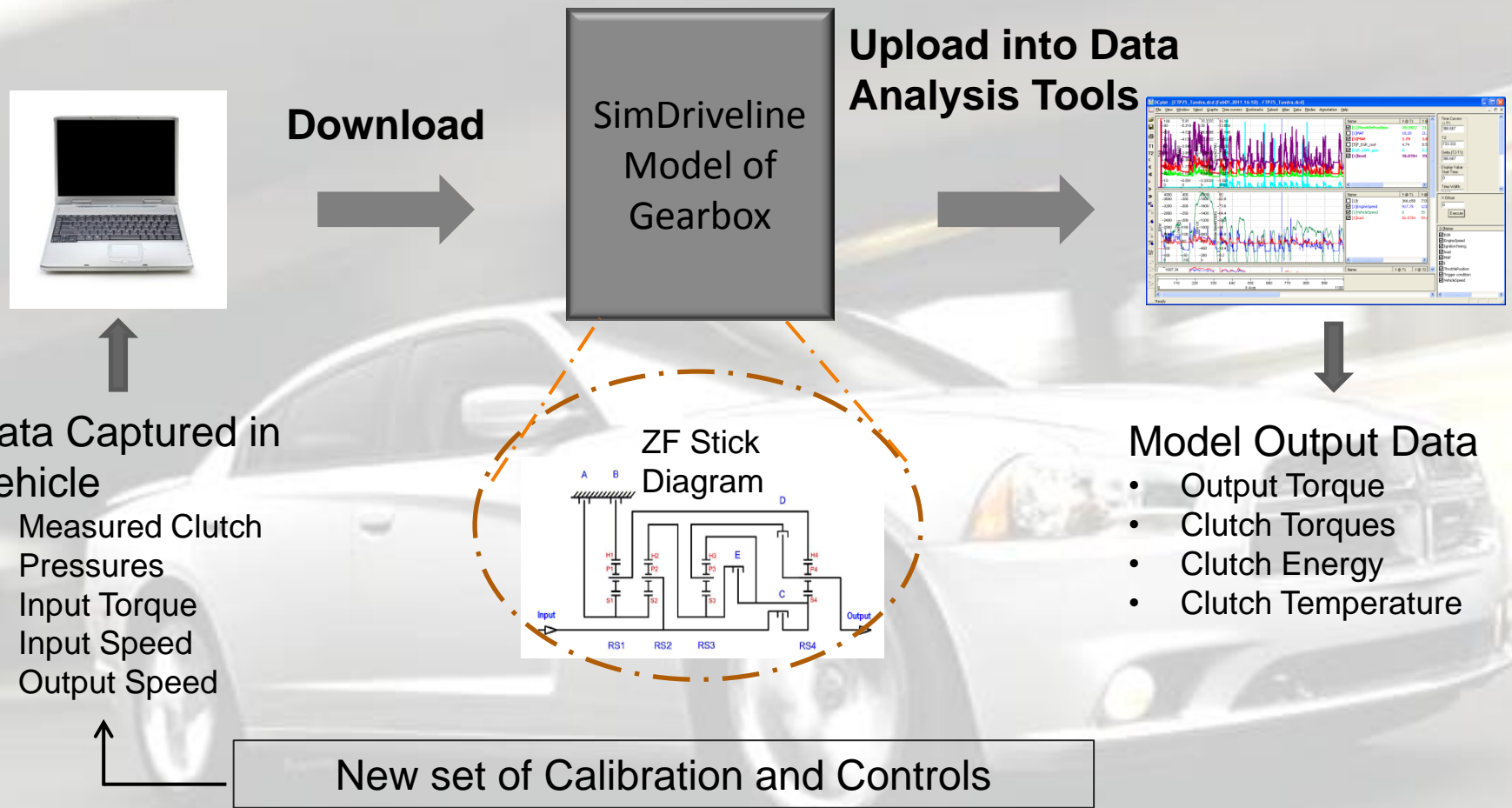

Controls Aid : Supports Analyzing Shift Dynamics and Physics
Calibration Aid : Evaluate Trends with Calibration Parameter Changes



Overall System Testing

- **Supplier Software function testing**
- **Hardware system testing**
- **System integration testing**

The problem is:

- 1) **Limited number of tests**
 - Vehicle Testing (Temp, altitude, weight, etc.)
 - Bench Testing
- 2) **Potentially some scenarios are never explored**



Current Tools and Approach

- FMEA and DVP&R are currently used to identify and test for a number of specifically designed scenarios.
- What's needed are tools to supplement FMEA and DVP&R that maximize the test coverage while minimizing the work load.
- In summary, we need much more exhaustive testing at the system level.



Overall System Software Testing

Different tools are required

- Tools should not require source code
- Only compiled code is needed from the supplier
- New tools are required to find:
 - Low level coding errors: Run time errors including division by zero, memory access violation, integer overflow and index out of bounds
 - System level errors: Poor shift quality, clutch overheating and inadequate fault reaction
 - Algorithmic errors: Oscillating and non converging controls



New Tools

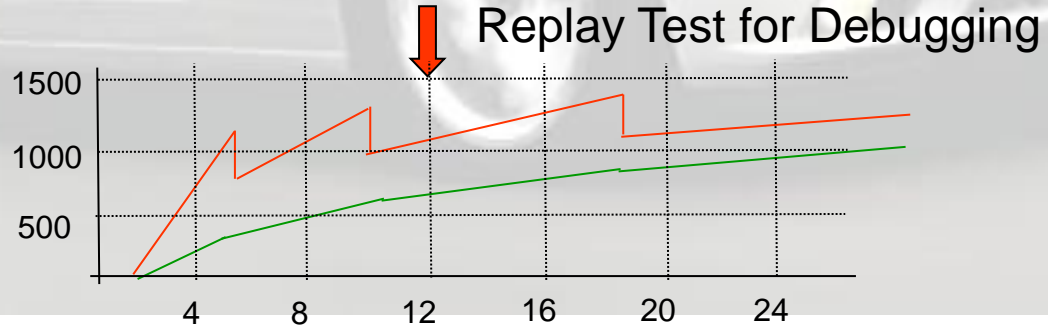
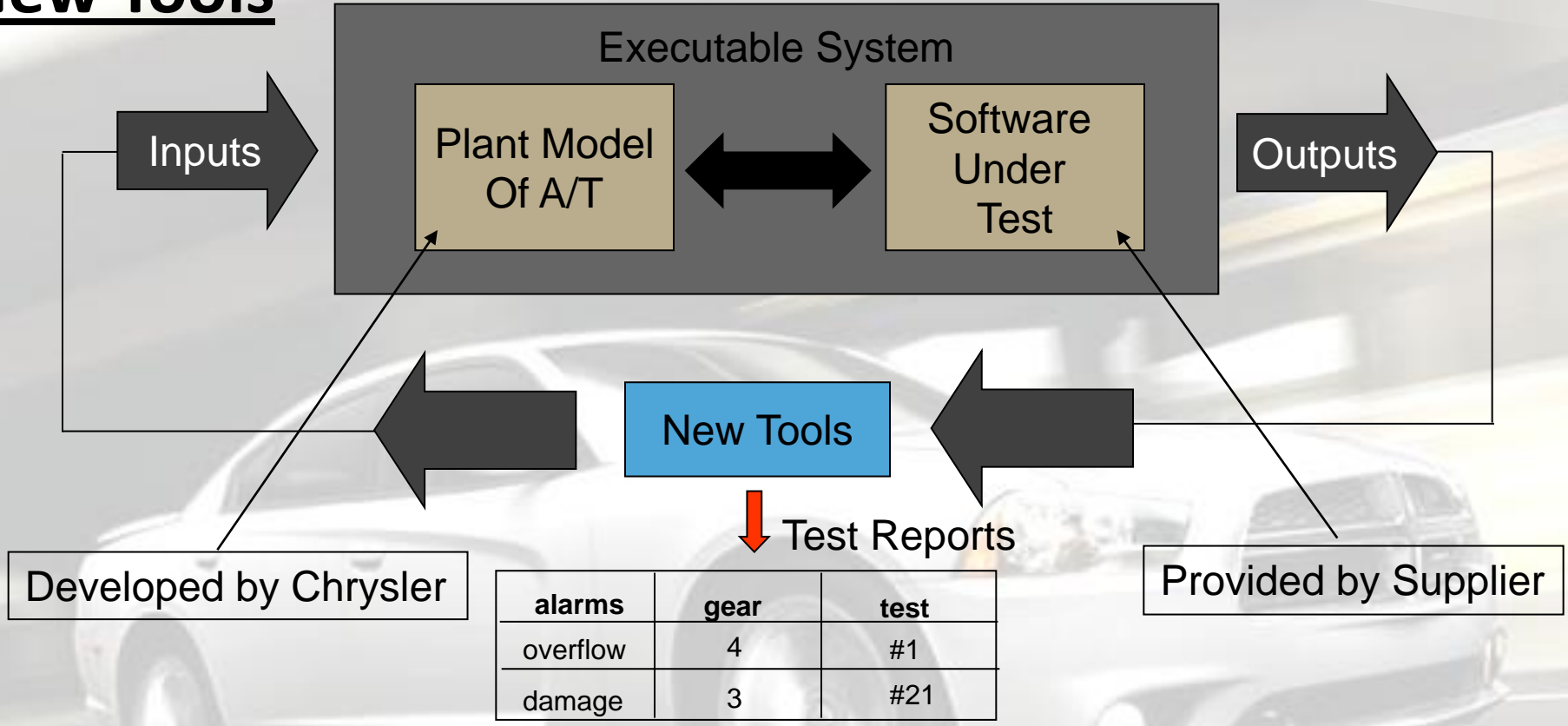

- Run tools which will drive the system into undesired states to maximize the coverage of the state space.
- The state space is the finite space spanned by all the inputs and outputs for the system.
- Every state is reached at least once.

Analyze the problems found. All of the problems found and the coverage reached is reported by tables and histograms. Every problem encountered can be replayed in the MIL environment for detailed debugging and analysis.

Percentage of Shifts Where Clutch is Damaged

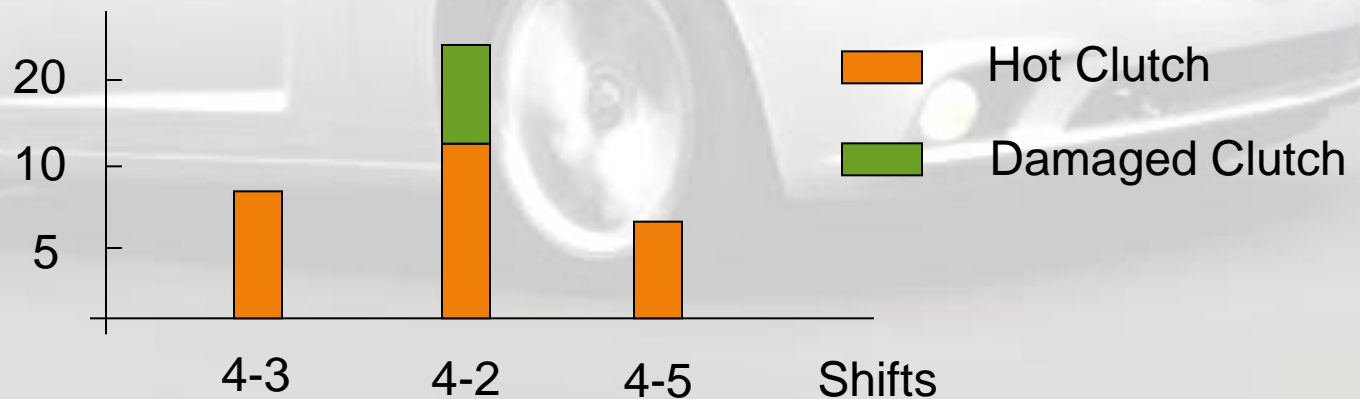

Integrating Chrysler Specific Features

- **AWD Driveline Integration with Front Axle Disconnect and Active Transfer Case.**
- **Thermal Management**
- **New and Advanced Powertrain Functions**



On-Demand Transfer Case with Front Axle Disconnect

- Transfer case and Front Axle Disconnect are controlled seamlessly between RWD and AWD modes
- AWD mode is activated automatically as weather or driving conditions dictate
- Customer benefits: Improved fuel economy, performance, handling, safety and capability

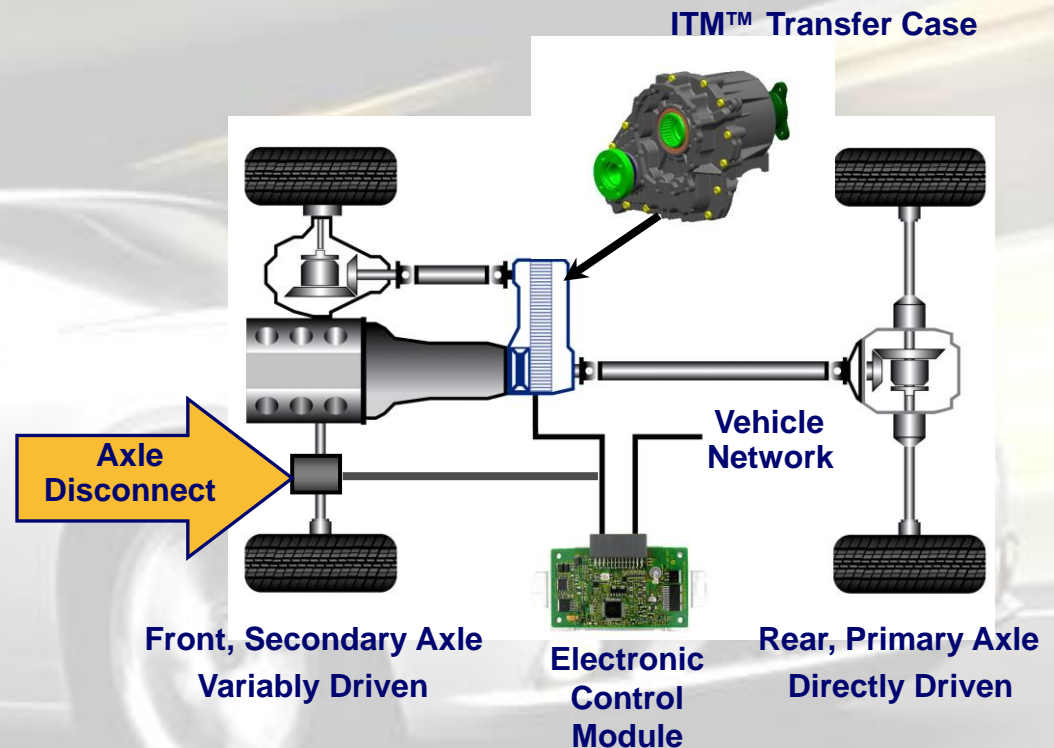

Transfer Case and Front Axle Disconnect are controlled seamlessly between 2WD or AWD modes based on pre-determined entrance/exit criteria:

- Ambient temperature
- Windshield wiper use
- Transmission mode
- ESP/TCS activity
- ESP mode



Powertrain Energy Distribution

Available Heat Energy

Cylinder
friction/combustion heat
carried by coolant

+

Combustion heat carried
by exhaust gas

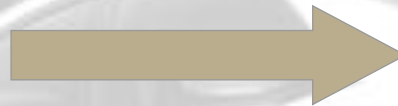

System of
heat
exchangers

Heat Energy Destination

Engine metal +
coolant + oil

Transmission
metal + oil

Atmosphere

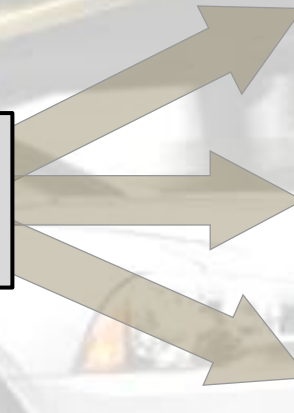

Simulation defines:

- Available energy from engine
- Distribution of available energy throughout EPA drive cycle
- Resulting warm-up times for engine and transmission



Thermal Management System

Total Heat Delivered for Warm Up Throughout EPA City Drive Cycle

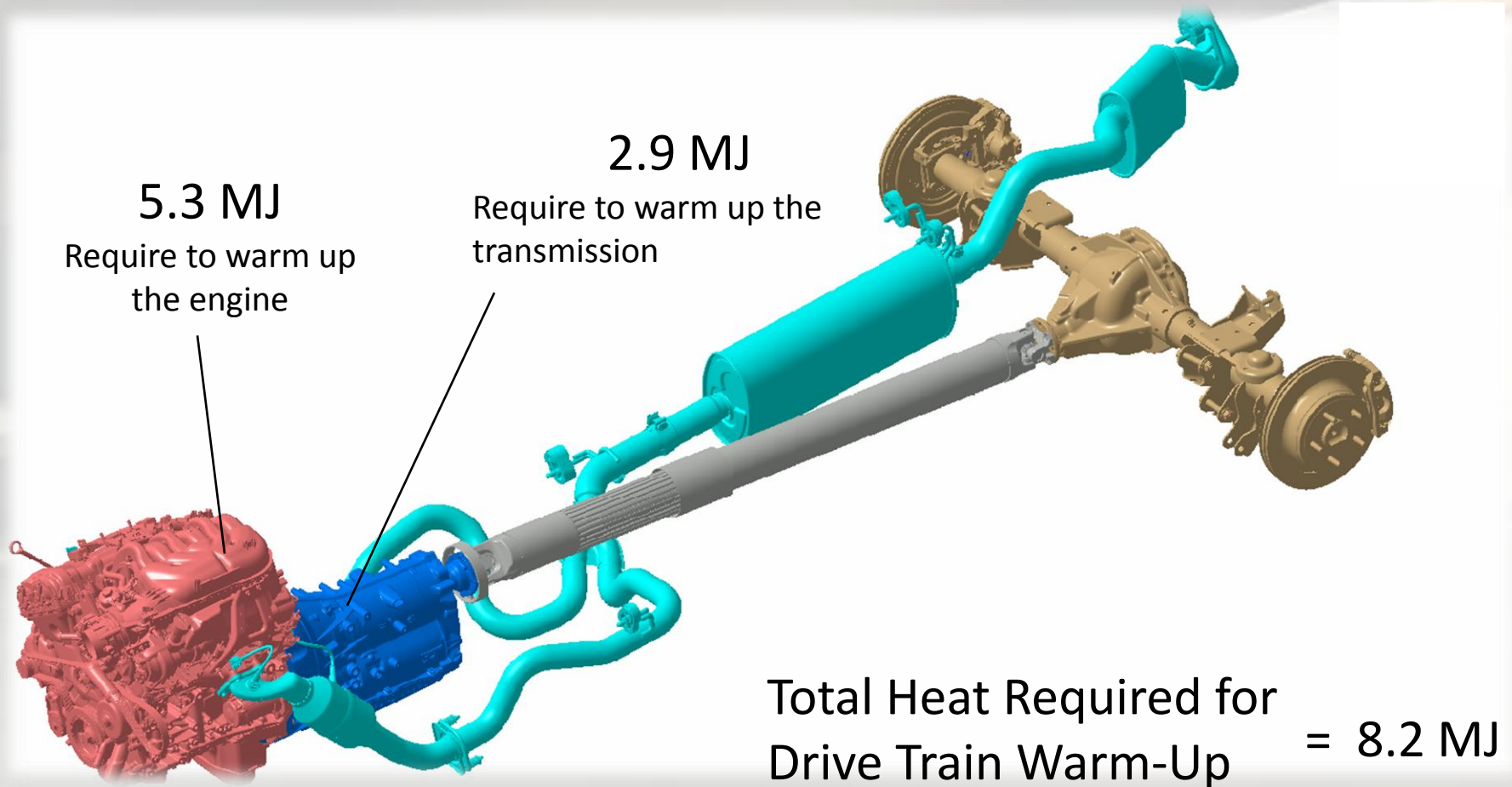

Typical EPA Combined FE Savings (%)

	Engine Oil Management	Trans Fluid Management	Axle Fluid Management	Total
Estimated				
FWD	1.0	1.6-2.0	N/A	2.6-3.0
RWD	1.0	1.5	0.5	2.5
Measured				
FWD	1.2	2.0	N/A	3.2
RWD	1.0	2.0	TBD	2.8



Active Chassis Controller

Engine Controller

Brake Controller

Transmission 8 Speed Controller

Drive Line Controller

Body Controller

CAN Bus Controller
Communication for a Full
System Integration

Specific Chrysler Features require communication from all controllers:

- 1) **IDFSO (Integrated Deceleration Fuel Shut Off)**
- 2) Thermal Management
- 3) **Shift Schedule Adaptation using Chrysler Vehicle Mass Calculation**
- 4) Interactive Coast Down/Shift Torque Management
- 5) AutoStick and Electronic Range Select
- 6) Selectrain (Sport, Snow, Mud, Sand, Rock Modes)



Interactive Deceleration Fuel Shutoff (IDFSO)

- The purpose of the IDFSO is to maximize the amount of engine fuel shutoff time for improved fuel efficiency.
- The amount of fuel shutoff can be increased by keeping the engine speeds high enough to prevent fuel rewet.
- This can be done by keeping the engine speed near turbine speed by engaging the torque converter clutch and/or by shifting to a lower gear.

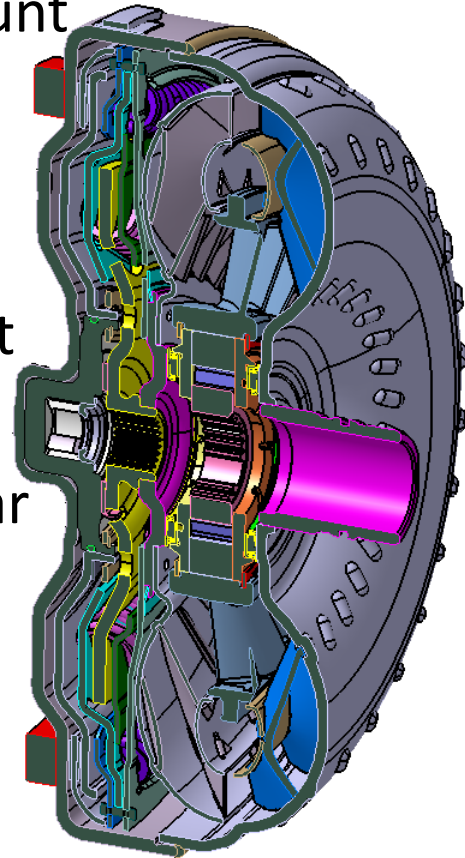

The interactive portion of the feature involves CAN communication between the engine and transmission controls for proper operation of the feature.



Chrysler Vehicle Mass calculation to improve driving strategy

Required Inputs to calculate mass:

- **Chassis** - Long acceleration and brake pressure, modeled brake torque
- **Engine** - Flywheel speed, modeled torque
- **Driveline** - Turbine and output speed, modeled losses

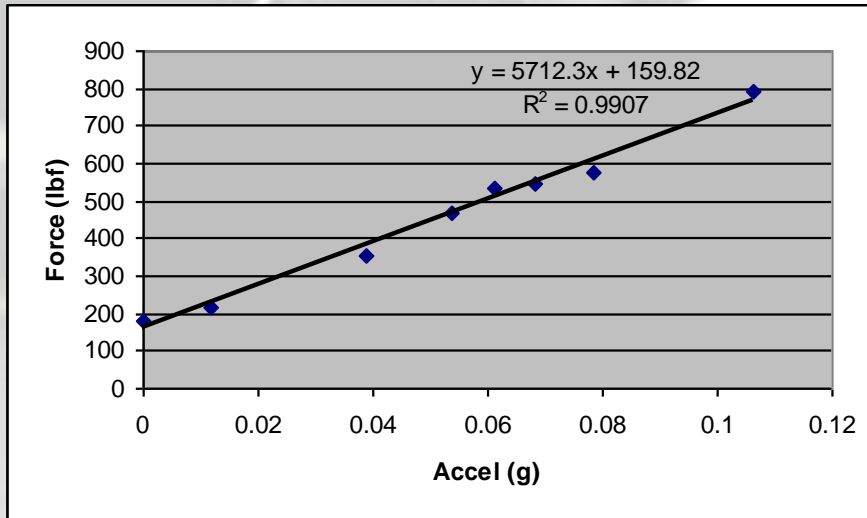

$$m = (F_2 - F_1) / (a_{Long2} - a_{Long1}) = \frac{\partial F}{\partial a}$$

$$F_{Drive} = A + B \cdot V_{Spd} + C \cdot V_{Spd}^2 + m \cdot a_{Long}$$



Improve NVH with A/C Engagement

- Engine requests the transmission to slip the Torque Converter Clutch (TCC) before the compressor engages.
- Transmission controls slip the TCC to a predetermined slip. This slip is designed to damp the shock coming from the compressor engagement.
- The Compressor engages.
- NVH is minimized
- Drivability is improved.



Conclusions

- **Regulatory requirements, driver preferences and specific needs, vehicle level functional attributes, and cost targets result in challenging and sometimes contradictory tasks for the Powertrain System engineering.**
- **A new business model requires a new approach in testing, calibration, and system integration.**
- **New innovative tools and methods are required.**
- **The business focus is on core system requirements and overall customer needs.**

